

PK-2 Schematic Diagram

Jackson Harbor Press
 RR1, Box 91C
 Washington Island, WI 54246
<http://home.att.net/~jacksonharbor>
 jacksonharbor@worldnet.att.net

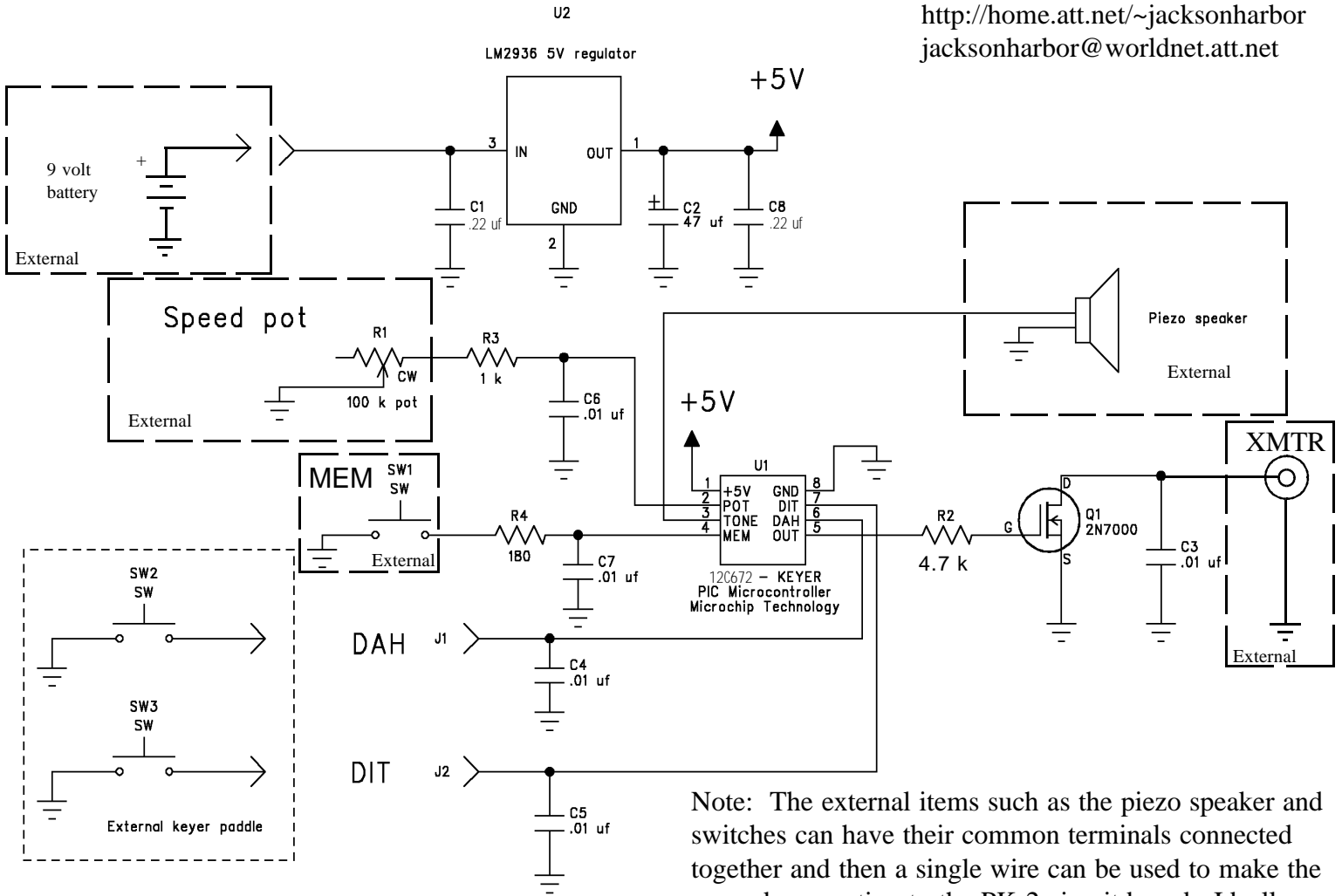

Note: The external items such as the piezo speaker and switches can have their common terminals connected together and then a single wire can be used to make the ground connection to the PK-2 circuit board. Ideally, the PK-2 will be housed in a metal case - the board mounted with a short metal standoff and star washers to insure a good electrical connection to ground.

Parts Placement Diagram

Top View of Circuit Board

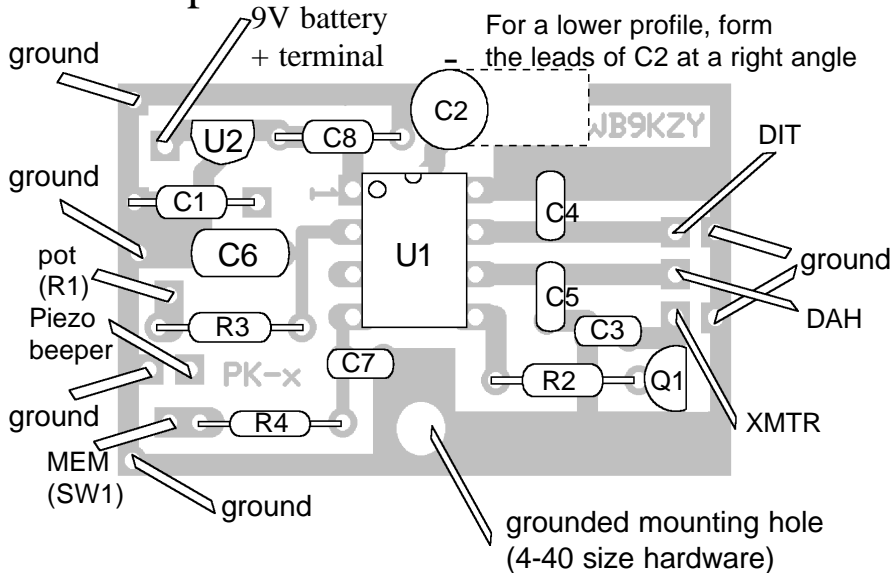

Bottom View of Circuit Board

